

Bseries

Bifurcated Fans

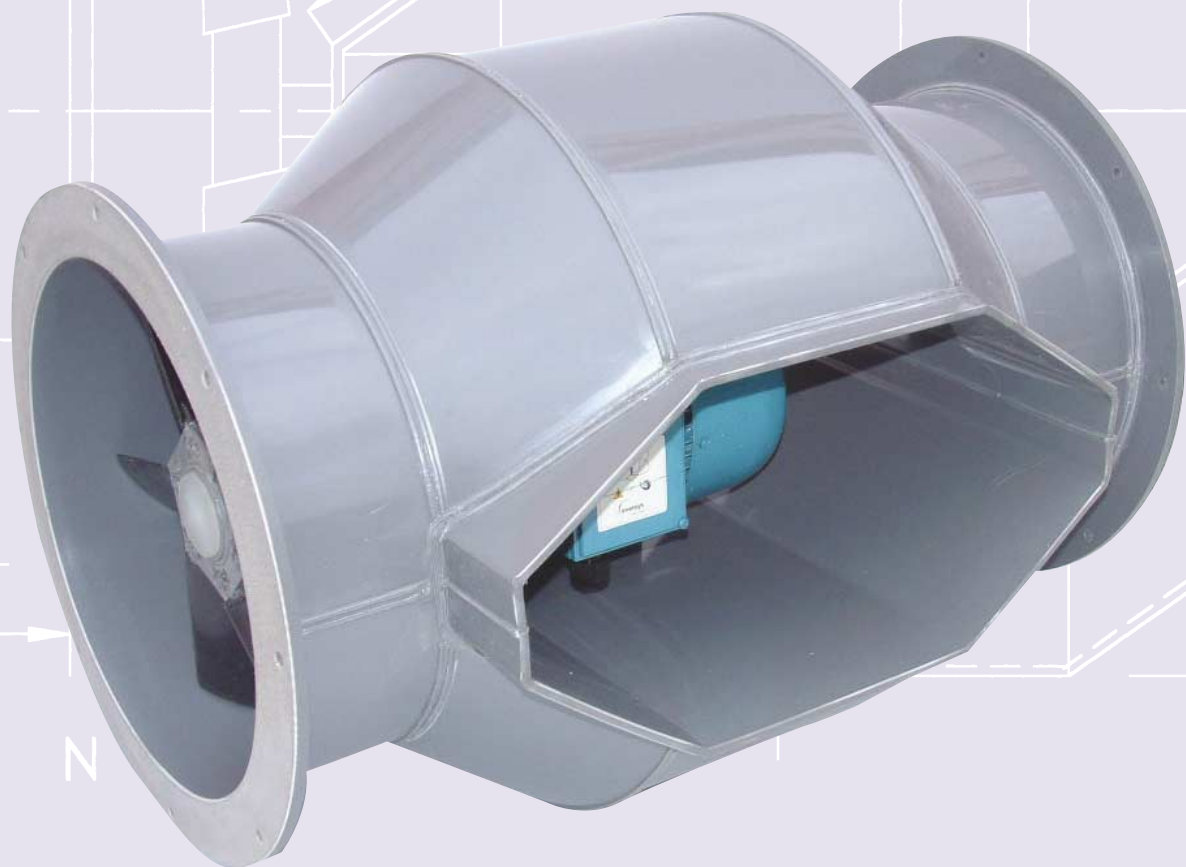

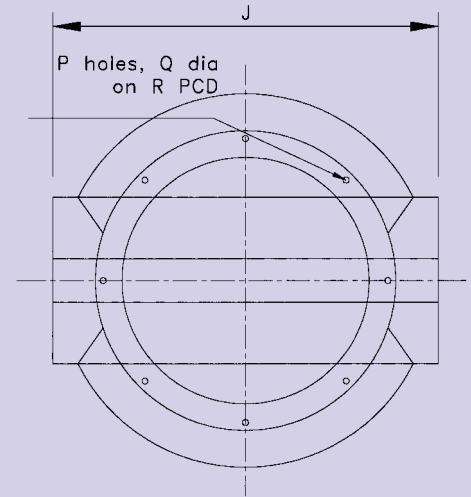
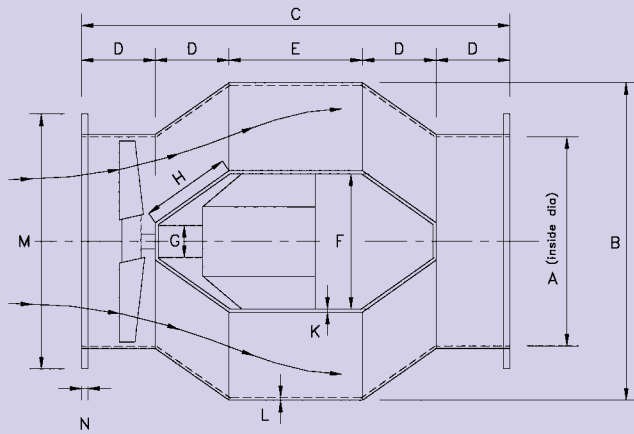

Size	A	B	C	D	E	F	G	H	J	K	L	M	N	P	Q	R
250	267	457	660	114	204	216	55	140	435	6	3	352	9	8	8	327
305	318	483	660	114	204	216	55	140	485	6	3	403	9	8	8	378
380	394	597	813	140	253	254	70	168	615	6	4.5	479	12	8	10	454
450	470	711	965	165	305	305	80	200	715	6	4.5	559	12	16	10	533
530	546	800	1118	191	354	330	100	223	805	6	4.5	635	12	16	10	610
610	622	889	1270	216	406	343	105	247	895	6	6	711	24	16	10	686
690	699	991	1270	203	458	356	115	236	1010	6	6	787	24	16	12	762
760	775	1041	1270	203	458	356	115	236	1075	6	6	865	24	16	12	840

All dimensions are in millimetres

B Series Specification

Inline Fume Extraction:

These Bifurcated fans are for a high volume, low resistance system. The unit can be installed at any angle in a duct line with its motor compartment, isolated from fumes.

For horizontal or near horizontal positions a drain plug can be fitted at the lowest part of the casing. To give even more flexibility the fans can be supplied in a belt driven arrangement.

Fan Casing

Fabricated from rigid PVC or Polypropylene.

Impeller

Multi-Wing design, moulded polypropylene.

Motors

Brook Crompton or equal, all in compliance with B.S. 5000 and B.S. 4999 with standard motors IP55 which can be upgraded to suit customer requirements.

General Specification

There are eight standard sizes in the bifurcated range B250 through to B760, giving volumes from 0.1m³/sec to 6m³/sec at pressures up to 490Pa. Mounting brackets, flexible connections and anti-vibration mountings to suit each unit are available if required.

Duty Information for Bifurcated Fans

FAN SIZE	MIN VOLUME m ³ /s	MAX VOLUME m ³ /s	MAX PRESSURE (Pa) AT MAX SPEED	MAX SPEED
B250	0.1	0.6	234	2800
B305	0.22	1.0	330	2800
B380	0.4	1.5	380	2800
B450	0.27	2.0	500	2800
B530	0.54	2.5	255	1440
B610	0.43	3.8	350	1440
B690	1.06	4.2	400	1440
B760	2.82	6.0	490	1440

APMG Limited operate a programme of continuous development and we reserve the right to change design, construction and dimensions without prior notice